

PRINT MAY BE REDUCED - DO NOT SCALE.

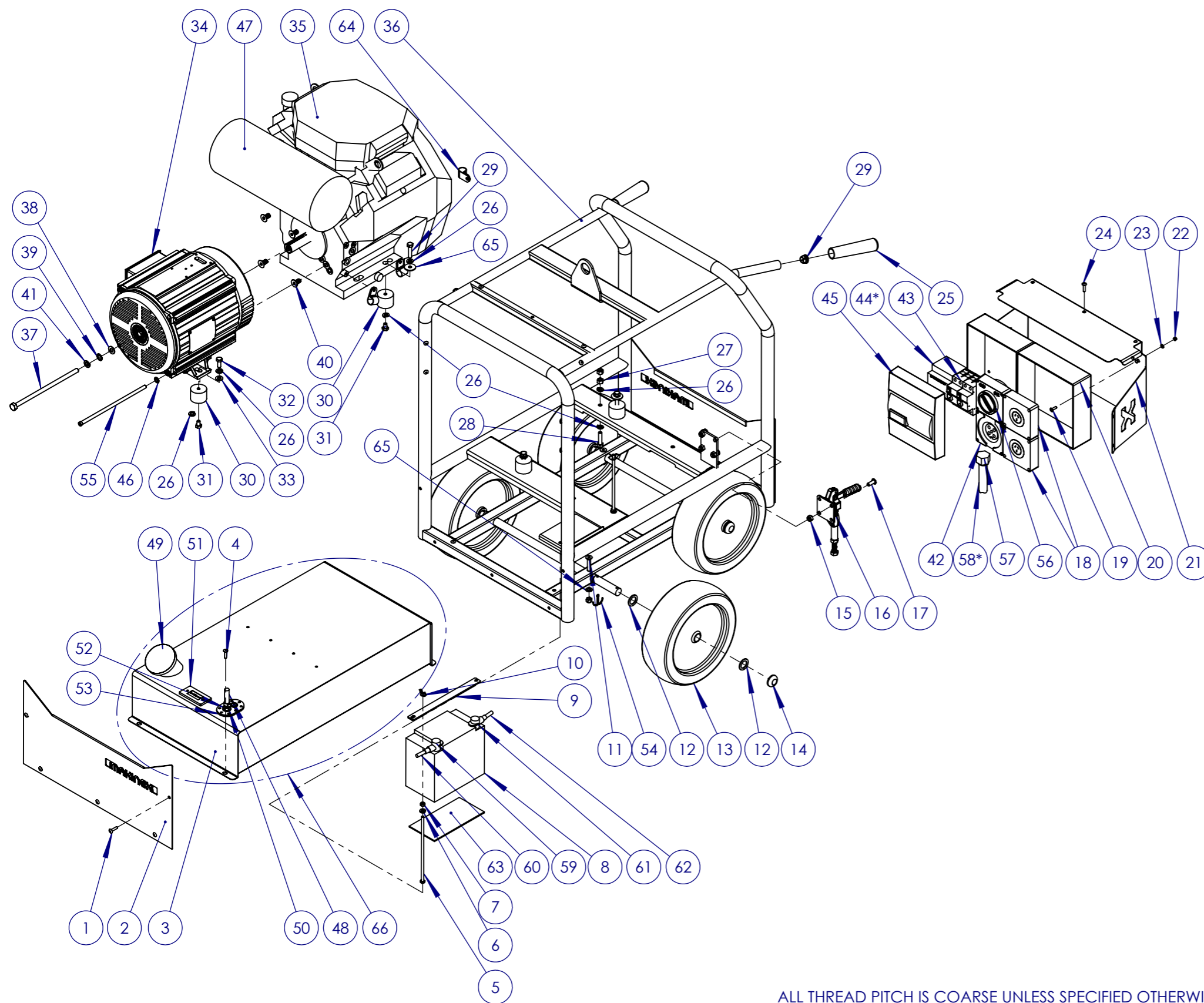

ALL THREAD PITCH IS COARSE UNLESS SPECIFIED OTHERWISE

ITEM NO.	PART NO.	PART NAME	QTY
1	MAK-UP-504	1/4" HUCK RIVET	10
2	GEN-16P-01-13	COVER PLATE	2
3	GEN-16P-13-01	FUEL TANK	1
4	MAK-UP-504	1/4" HUCK RIVET	4
5	MAK-UP-505	M6 x 200MM THREADED ROD	2
6	MAK-UP-506	M6 SPRING WASHER	6
7	MAK-UP-507	M6 NUT	5
8	MAK-UP-28	BATTERY 12V	1
9	GEN-16P-01-14	BATTERY BAR	1
10	MAK-UP-508	M6 WING NUT	2
11	MAK-UP-683	M8 x 40 CS BOLT	2
12	MAK-UP-06	M20 NYLON WASHER	20
13	GEN-16P-03-03	DIA 265 WHEELS	4
14	MAK-UP-04	20MM AXLE CAP	4
15	MAK-UP-511	M8 NYLOC NUT	6
16	GEN-16P-01-21	TOGGLE CLAMP (BRAKE)	1
17	MAK-UP-512	M8X20 BUTON SOCKET HEAD	4
18	MAK-UP-77	SINGLE PHASE OUTLET 15A	2
19	MAK-UP-513	M5 x 16 BUTON SOCKET HEAD	4
20*	MAK-UP-102	MOUNTING BOX, 8 MODULE (168MMX195MM)	1
	MAK-UP-103	MOUNTING BOX, 8 MODULE (192MMX193MM)	1
21	GEN-16P-01-15	SWITCH BOX BRACKET	1
22	MAK-UP-514	M5 NYLOC NUT	4
23	MAK-UP-515	M5 FLAT WASHER (MEDIUM)	4
24	MAK-UP-504	1/4" HUCK RIVET	9
25	MAK-UP-07	RUBBER HANDLE GRIP	2
26	MAK-UP-516	M8 SPRING WASHER	3
27	MAK-UP-517	M8 NUT	2
28	MAK-UP-518	M8 x 35 HEX BOLT	3
29	MAK-UP-175	HANDLE END PLUG	2
30	MAK-UP-25	ENGINE MOUNT	4
31	MAK-UP-519	M8x12 HEX BOLT	4
32	MAK-UP-520	M8X20 HEX BOLT Z/P	2
33	MAK-UP-521	M8 FLAT WASHER (LARGE)	2
34	RF2-17.5-2	415V ALTERNATOR 17.5kW	1
35	GX690-RH-VXE1	ENGINE - HONDA GX690 E-START	1
36	GEN-16P-01W	FRAME WELDMENT	1
37	MAK-UP-522	5/16" - 8.5" UNF HEX HIGH TENSILE BOLT	1
38	MAK-UP-523	5/16" HIGH TENSILE WASHER	1
39	MAK-UP-524	5/16" SERRATED WASHER	1
40	MAK-UP-525	3/8" - 16 x 3/4" CS BOLT	4
41	MAK-UP-526	5/16" SPRING WASHER	1
42	MAK-UP-75	32A 5 PIN 3 PHASE SOCKET	1
43	MAK-UP-89	SINGLE PHASE RCBO 16A	2
44*	MAK-UP-27	3 PHASE RCBO 32A C CURVE	1
	MAK-UP-27-1	(OPTIONAL) 3 PHASE RCBO 32A D CURVE	1
45	MAK-UP-97	ENCLOSURE COVER, 4 MODULE (168MMX195MM)	1
	MAK-UP-105	ENCLOSURE COVER, 4 MODULE (192MMX193MM)	1
46	MAK-UP-516	M8 SPRING WASHER	4
47	06183-Z6L-010	MUFFLER	1
48	GEN-16P-13-02	1/4" FUEL LINE (FUEL TANK TO ENGINE)	1
49	GEN-16P-13-04	FUEL CAP	1
50	GEN-16P-01-22	1/4" EAR CLAMPS	4
51	GEN-16P-13-05	FUEL GAUGE	1
52	GEN-16P-13-08	FUEL TOP NIPPLE	1
53	GEN-16P-13-09	FUEL TOP NIPPLE COVER	1
54	MAK-UP-566	4MM SPLIT PIN	4
55	MAK-UP-586	M8X230 HEX BOLT Z/P	4
56	GENS-04-09	3 PHASE SWITCH 32A	1
57	MAK-UP-108	STRAIGHT GLAND 25MM	1
58	MAK-UP-153	CONDUIT 25MM	1
59	MAK-UP-111	TERMINAL COVER BLACK	1
60	GEN-16P-10-02	BATTERY CABLE NEGATIVE 300MM	1
61	MAK-UP-110	TERMINAL COVER RED	2
62	GEN-16P-10-01	BATTERY CABLE POSITIVE 750MM	1
63	MAK-UP-46	BATTERY PADDING (151x86)	1
64	MAK-UP-156	P-CLIPS 13MM	3
65	MAK-UP-535	M8 FLAT WASHER (MEDIUM)	4
66	GEN-16P-13-00	8 GAL FUEL TANK ASSEMBLY RED	1



Sydney (Head Office) Ph: 1300 795 953
 15 Waltham St Fax: (02) 9439 9815
 Artarmon, 2064 www.makinex.com.au
 NSW, Australia sales@makinex.com.au

COPYRIGHT 2015 MAKINEX.
 WARNING: Copyright in this drawing remains the property of MAKINEX and copying in whole or part is not permitted without the written authority of the copyright owner.

GENERAL TOLERANCES
 (Unless otherwise noted)
 0-100mm: ± 0.25 mm
 100mm - 500mm: ± 0.5 mm
 500mm +: ± 1.0 mm
 Angular: ± 1 deg.

Third Angle Projection
 - AS 1100

DATE: 09/26/19

SCALE: D.N.S A3

All Dimensions are in Millimetres
 Break All Sharp Corners and
 Remove Burrs & Swarf



PROJECT:

DWG NO.

GEN-16P-AU

NOTES:

TITLE

GENERATOR, 16kVA PETROL, 32A, AUS SPEC

MATERIAL

SEE PARTS

FINISH

SEE PARTS

DRN: JT

MASS

REV

004

SHEET 1 OF 3

PRINTED: 09/26/19

PRINT MAY BE REDUCED - DO NOT SCALE.

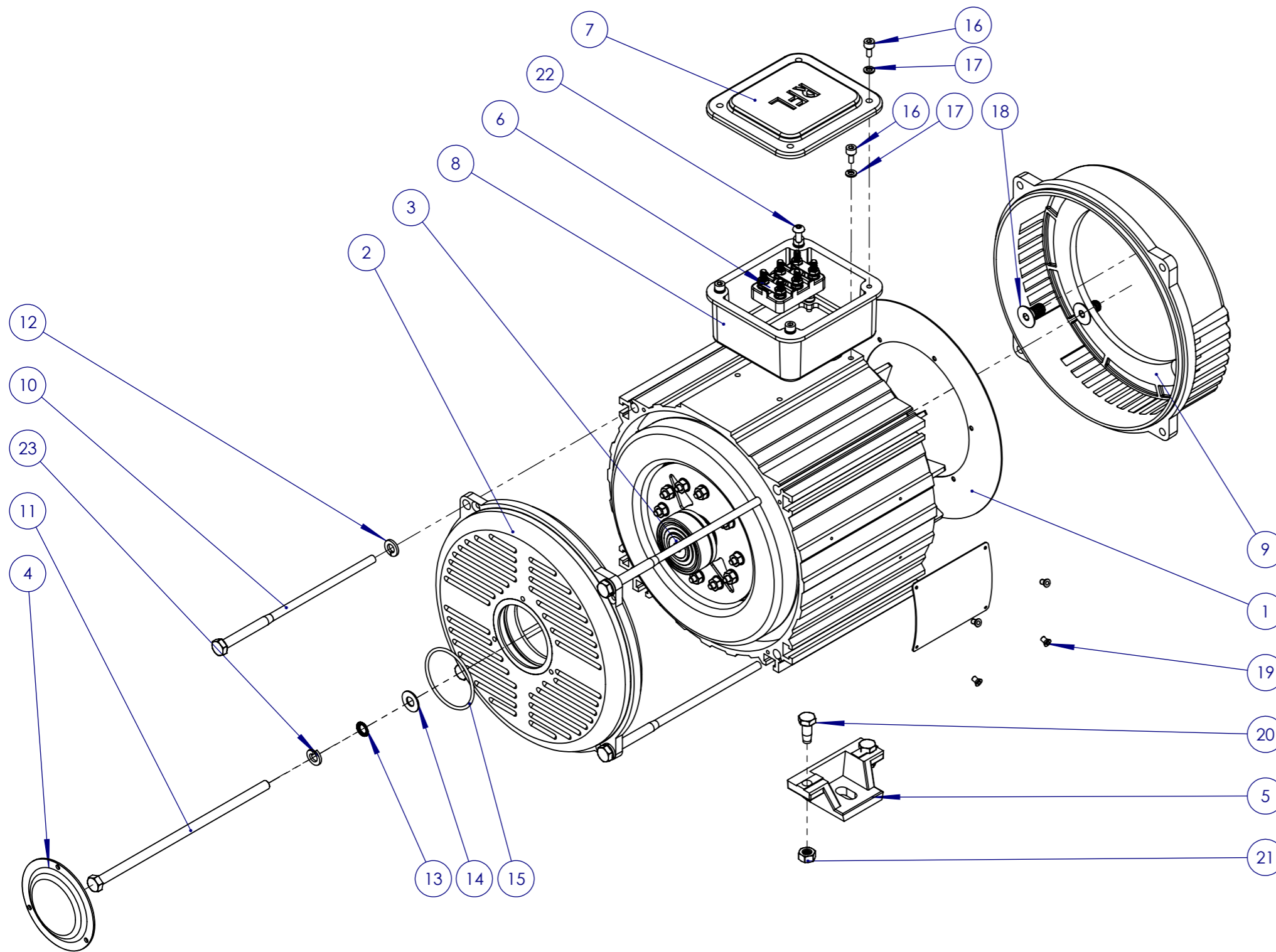

ITEM NO.	PART NO.	PART NAME	QTY
1	RF0056	FAN PLATE	1
2	RF0003	END CAP	1
3	MAK-UP-26	ALTERNATOR END SHAFT BEARING	1
4	RF0114	BOLT CAP	1
5	RF0014	LEG	2
6	RF0061	TERMINAL BLOCK	1
7	RF0013	TERMINAL BOX LID & RUBBER	1
8	RF0012	TERMINAL BOX	1
9	RF0008	CASING FLANGE, J609	1
10	MAK-UP-586	M8X230 HEX BOLT Z/P	4
11	MAK-UP-522	5/16" - 24X8.5" UNF HIGH TENSILE BOLT	1
12	MAK-UP-516	M8 SPRING WASHER	4
13	MAK-UP-524	5/16" SERRATED WASHER	1
14	MAK-UP-523	5/16" HIGH TENSILE WASHER	1
15	P5002	M54 O-RING	1
16	MAK-UP-578	M5X16 SOCKET HEAD CAPSCREW Z/P	8
17	MAK-UP-632	M5 SPRING WASHER	8
18	MAK-UP-525	3/8" - 16X3/4" CS BOLT	4
19	MAK-UP-634	5/32" BLIND RIVET	4
20	MAK-UP-519	M8X12 HEX BOLT Z/P	4
21	MAK-UP-511	M8 NYLOC NUT	4
22	MAK-UP-609	M5X12 BUTTON HEAD SOCKET Z/P	2
23	MAK-UP-526	5/16" SPRING WASHER	1

ALL THREAD PITCH IS COARSE UNLESS SPECIFIED OTHERWISE



Sydney (Head Office) Ph: 1300 795 953
 15 Waltham St Fax: (02) 9439 9815
 Artarmon, 2064 www.makinex.com.au
 NSW, Australia sales@makinex.com.au

COPYRIGHT 2015 MAKINEX.
 WARNING: Copyright in this drawing remains the property of MAKINEX and copying in whole or part is not permitted without the written authority of the copyright owner.

GENERAL TOLERANCES
 (Unless otherwise noted)
 0-100mm: ± 0.25 mm
 100mm - 500mm: ± 0.5 mm
 500mm +: ± 1.0 mm
 Angular: ± 1 deg.

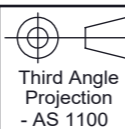

DATE: 09/26/19

SCALE: D.N.S A3

All Dimensions are in Millimetres
 Break All Sharp Corners and
 Remove Burrs & Swarf



PROJECT:

DWG NO.

NOTES:

TITLE

RF2-17.5-2 ALTERNATOR, 16kVA, 415V, 50Hz

MATERIAL

SEE PARTS

FINISH

SEE PARTS

DRN: JT

MASS

REV

002

SHEET 2 OF 3

PRINTED: 09/26/19

PRINT MAY BE REDUCED - DO NOT SCALE.

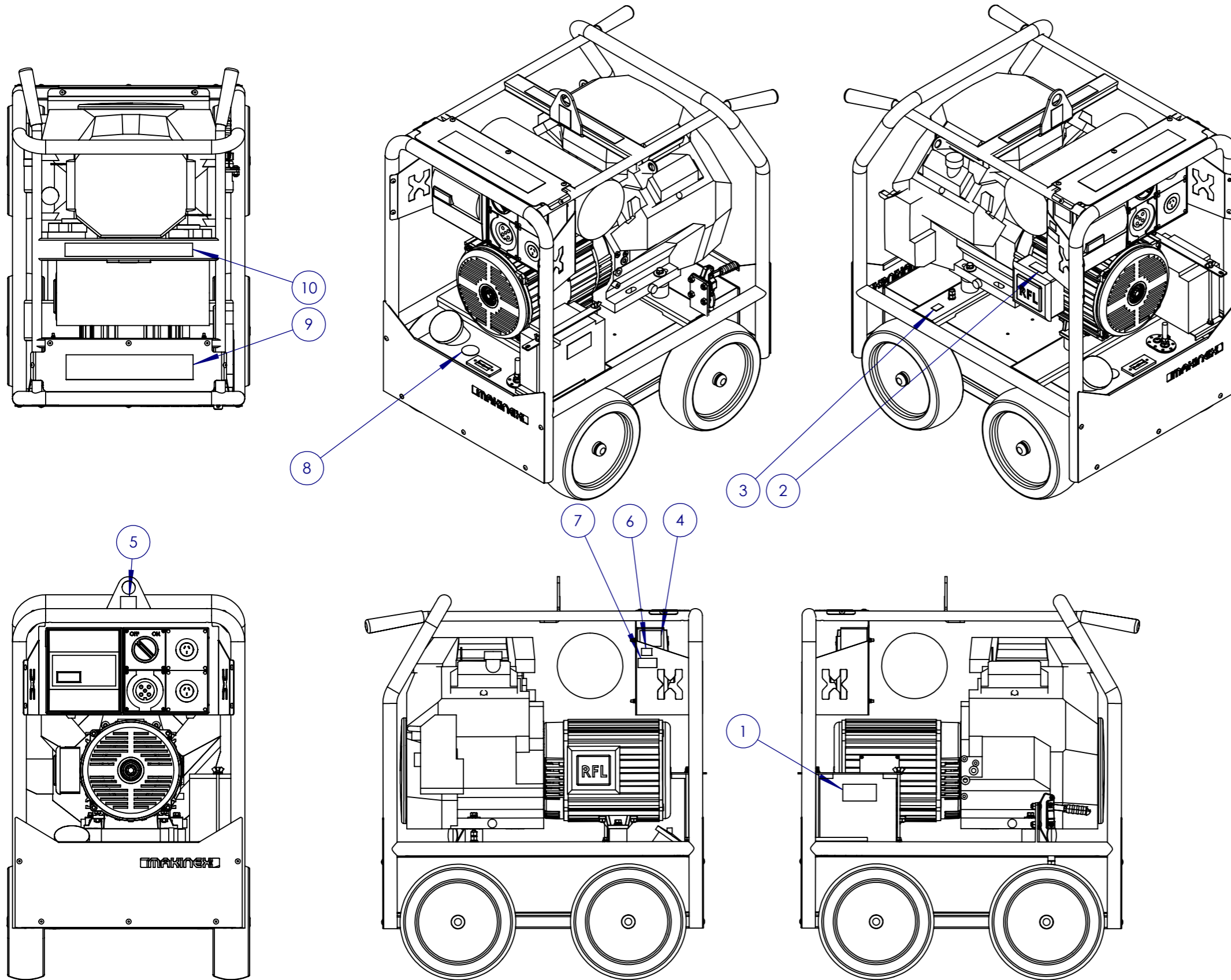

ITEM NO.	PART NO.	PART NAME	QTY
1	MAK-UP-95	STICKER-BATTERY LIFE WARNING	1
2	MAK-UP-186	STICKER-DANGER 415 VOLTS	1
3	MAK-UP-93	STICKER-EARTH	1
4	MAK-UP-91	STICKER-DANGER HIGH VOLTAGE	1
5	MAK-UP-16	STICKER-LIFTING POINT	1
6	MAK-UP-17	STICKER-MAKINEX SERVICE	1
7	MAK-UP-15	STICKER-MAKINEX SERIAL NUMBER	1
8	MAK-UP-94	STICKER-RE-FUEL WARNING	1
9	GEN-16P-08-01	STICKER-INSTRUCTION	1
10	MAK-UP-12	STICKER-MAKINEX LARGE	1



Sydney (Head Office) Ph: 1300 795 953
 15 Waltham St Fax: (02) 9439 9815
 Artarmon, 2064 www.makinex.com.au
 NSW, Australia sales@makinex.com.au

COPYRIGHT 2013 MAKINEX.
 WARNING: Copyright in this drawing remains the property of MAKINEX and copying in whole or part is not permitted without the written authority of the copyright owner.

GENERAL TOLERANCES
 (Unless otherwise noted)
 0-100mm: ± 0.25 mm
 100mm - 500mm: ± 0.5 mm
 500mm +: ± 1.0 mm
 Angular: ± 1 deg.

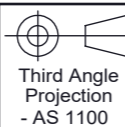

DATE: 09/26/19

SCALE: D.N.S A3

All Dimensions are in Millimetres
 Break All Sharp Corners and
 Remove Burrs & Swarf

25
 Denotes Critical Dimension

PROJECT:

DWG NO.

GEN-16P-AU

NOTES:

TITLE

GENERATOR, 16kVA PETROL, 32A, AUS SPEC

MATERIAL

SEE PARTS

FINISH

SEE PARTS

DRN: JT

MASS

REV

004

SHEET 3 OF 3

PRINTED: 09/26/19